

AvantGuard R1200 R/RS_LC Installation Guide

908. 996. 7210 x14

sales@machineartmoto.com

*** BEFORE BEGINNING WORK, READ THESE INSTRUCTIONS FROM START TO FINISH.**

*** PLACE BIKE ON CENTER STAND ON LEVEL GROUND.**

*** YOU WILL NEED ACCESS TO THE BOTTOM OF THE ENGINE TO DO THE INSTALLATION. PREPARE A FLOOR PAD FOR COMFORT AS NEEDED.**

Tools Required:
T25 Torx screw driver
13mm socket wrench

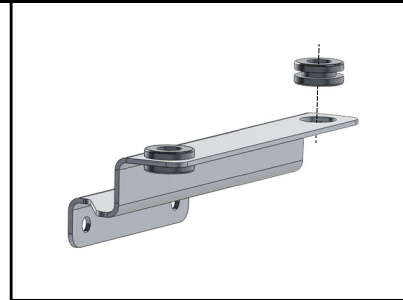

1 Install a rubber grommet into each of the large holes in the aluminum bracket.

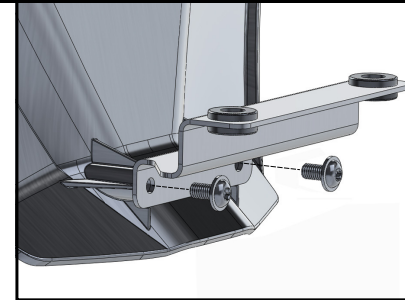

2 Attach aluminum bracket to the AVG using two M5 flange screws with a T25 Torx driver.

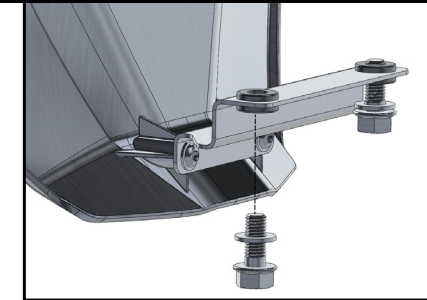

3 Insert Hex Bolts with washers partially into the rubber grommets. Grommets will hold the Bolts in place.

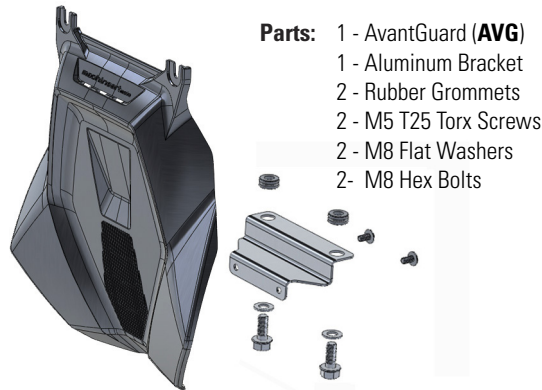

Parts: 1 - AvantGuard (AVG)
1 - Aluminum Bracket
2 - Rubber Grommets
2 - M5 T25 Torx Screws
2 - M8 Flat Washers
2 - M8 Hex Bolts



4 Loosen two T25 Torx screws securing the front cover & radiator 3-4 turns. DO NOT REMOVE.

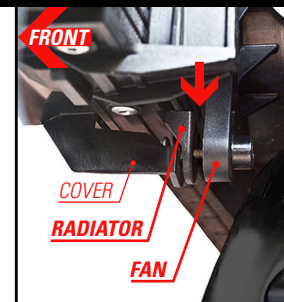

5 Spread apart the fan and radiator mounts.

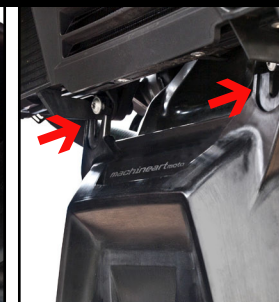

Insert two forked mounting tabs of the AVG in between the fan & radiator mounts.

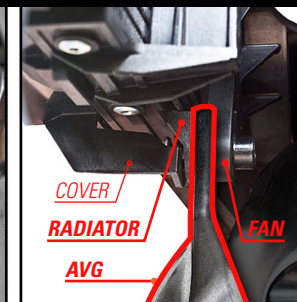

AVG shown mounted correctly. **NOTE:** it does NOT fit between radiator and cover mounts.

WARNING AND DISCLAIMER: All parts manufactured, designed or sold by Machineart Moto ("MaMo") should be installed by a qualified motorcycle technician. The risk of injury is increased by improper installation or misuse of equipment. MaMo's customers must exercise good judgment in the use, control, alteration, part selection and installation, and maintenance of their motorcycles. In the event of a possible defect in material or design, or any other defect in a part manufactured, designed or sold by MaMo, the responsibility of MaMo is limited to a refund of the purchase price or the replacement of the part if MaMo determines the part to be defective, and subject to MaMo's inspection of the part within thirty (30) days from the date of purchase. (Note: any attempted repairs or modifications made to MaMo products will void this limited warranty). MaMo, under no circumstances will be responsible for incidental and/or consequential damages, property damage, personal injury damage, or damage, injury, cost or expense of any kind or nature whatsoever except as provided by law. MaMo makes no other warranty, express or implied, including without limitation any warranties of merchantability and fitness for a particular purpose.



6 Align Hex Bolts with the two threaded holes in the bottom of the engine and start to screw them in by hand.



7 Tighten Hex bolts with a 13mm socket wrench.



8 Finally, tighten the two T25 Torx screws securing the forked mounting tabs. Check alignment.